

DICOM Conformance Statement

INSPIRA

PENTAX Medical Video Processor

EPK-i8020c System Version : 1.0032

Conformance Statement

Manufacturer

HOYA Corporation
6-10-1 Nishi-shinjuku,
Shinjuku-ku, Tokyo
160-0023 Japan

© HOYA Corporation All rights reserved.

The information in this publication may be changed at any time, without prior notice. While technical inaccuracies, typographical errors, and editorial omissions may occur, PENTAX of America, Inc. disclaims all direct, indirect or consequential damages that may result from such errors. PENTAX of America, Inc. will make every effort to correct the deficiencies of this document in new editions.

HOYA Corporation



#	EPK-i8020c
---	------------

6-10-1 Nishi-shinjuku,
Shinjuku-ku, Tokyo
160-0023 Japan

EC	REP
----	-----

PENTAX Europe GmbH
Julius-Vosseler-Straße 104
22527 Hamburg, Germany
[Tel:+49 40 561 92-0](tel:+4940561920)
Fax:+49 40 560 42 13

PENTAX Medical Shanghai Co., Ltd.
Room 701, 291 Fumin Road, Shanghai
200031 P.R. China
[Tel:+86 21 6170 1555](tel:+862161701555)
Fax:+86 21 6170 1655

PENTAX Medical
A Division of PENTAX America, Inc.
3 Paragon Drive
Montvale, NJ 07645-1782
USA
[Tel:+1 201 571 2300](tel:+12015712300)
Toll Free:+1 800 431 5880
Fax:+1 201 391 4189

PENTAX Medical Singapore Pte. Ltd.
438A Alexandra Road, #08-06
Alexandra Technopark, 119967 Singapore
[Tel:+65 6507 9266](tel:+6565079266)
Fax:+65 6571 1691
Customer Service Toll Free:
400 102 0968 (within China)
1800 2005 968 (within India)
1300 PENTAX (within Australia)

Table of contents

1. Conformance Statement Overview	5
2. Introduction.....	6
2-1 Revision History	6
2-2 Audience	6
2-3 Remarks.....	7
2-4 Definitions, Terms, and Abbreviations.....	7
2-5 References.....	8
3. Networking	9
3-1 Implementation Model	9
3-1-1 Application Data Flow	9
3-1-2 Functional Definition of EPK-i8020c AEs	11
3-1-3 Sequencing of Real-World Activities	12
3-2 AE Specifications	13
3-2-1 EPK-i8020c Verification Application Entity Specification SOP Classes	13
3-2-2 EPK-i8020c Storage Application Entity Specification SOP Classes.....	17
3-2-3 EPK-i8020c Storage Commitment Application Entity Specification SOP Classes.....	22

3-2-4	EPK-i8020c Worklist Application Entity Specification SOP Classes	27
3-2-5	EPK-i8020c Modality Performed Procedure Step Application Entity Specification SOP Classes	
	33	
3-2-6	Association Acceptance Policy	39
3-3	NETWORK INTERFACES.....	40
3-3-1	Physical Network Interface	40
3-3-2	Additional Protocols	40
3-4	CONFIGURATION.....	41
3-4-1	AE Title/Presentation Address Mapping Local AE Titles	41
4.	Support of Character Sets.....	42
5.	Security.....	43
6.	Appendix	44
6-1	VL Endoscopic Image Storage IOD specifications	44
6-2	Secondary Capture Image Storage IOD specifications	46

1. Conformance Statement Overview

The Pentax Medical EPK-i8020c implements the DICOM services necessary to download Worklists from an information system, save acquired images (stills, videos) to a network storage device, and inform the information system about the completed examination.

Table 1 provides an overview of the network services supported by EPK-i8020c.

Table 1. Network Services

SOP Classes	User of Service (SCU)	Provider of Service (SCP)
Transfer		
VL Endoscopic Image Storage	Yes	No
Secondary Capture Image Storage	Yes	No
Storage Commitment Push Model	Yes	No
Verification		
Verification	Yes	Yes
Worklist Management		
Modality Worklist Information - Model FIND	Yes	No
Modality Performed Procedure Step	Yes	No

The SOP Classes are categorized as follows:

Table 2. UID Values

UID Value	UID NAME	Category
1.2.840.10008.5.1.4.1.1.77.1.1	VL Endoscopic Image Storage	Transfer
1.2.840.10008.5.1.4.1.1.7	Secondary Capture Image Storage	Transfer
1.2.840.10008.1.20.1	Storage Commitment Push Model	Transfer
1.2.840.10008.5.1.4.31	Modality Worklist Information Model - FIND	Worklist Management
1.2.840.10008.3.1.2.3.3	Modality Performed Procedure Step	Worklist Management
1.2.840.10008.1.1	Verification	Verification

2. Introduction

This chapter provides general information about the purpose, scope and contents of this Conformance Statement.

2-1 Revision History

Document Version	Date of Issue	Description
00	Dec. 22, 2022	Initial version

2-2 Audience

This document is intended for the following audience:

- Current or potential customers
- Hospital Information Analysts
- Hospital staff, health system integrators
- Software designers or implementers
- Pentax Medical Field Service Technicians

It is assumed that the reader is familiar with the DICOM standard has a working understanding of DICOM.

2-3 Remarks

DICOM, by itself, does not guarantee interoperability. However, the Conformance Statement facilitates a first-level validation for interoperability between different applications supporting the same DICOM functionality.

The scope of this Conformance Statement is to facilitate communication with EPK-i8020c (products) and other vendors' Medical equipment. The Conformance Statement should be read and understood in conjunction with the DICOM Standard. However, by itself it is not guaranteed to ensure the desired interoperability and a successful interconnectivity.

The user should be aware of the following important issues:

- The comparison of different conformance statements is the first step towards assessing interconnectivity between EPK-i8020c and non- EPK-i8020c equipment
- Test procedures should be defined to validate the desired level of connectivity
- The DICOM standard will evolve to meet the users' future requirements. EPK-i8020c are actively involved in developing the standard further and therefore reserve the right to make changes to its products or to discontinue its delivery

2-4 Definitions, Terms, and Abbreviations

Definitions, terms and abbreviations used in this document are defined within the different parts of the DICOM standard.

Abbreviations and terms are as follows:

- AE: Application Entity
- DICOM: Digital Imaging and Communications in Medicine
- GUI: Graphical User Interface
- HIS: Hospital Information System
- HL7: Health Industry Level 7 Interface Standard
- IHE: Integrating the Healthcare Enterprise
- IOD: Information Object Definition
- IP: Internet Protocol
- JPEG: Joint Photographic Experts Group
- NEMA: National Electrical Manufacturers Association
- PACS: Picture Archiving and Communications System
- RIS: Radiology Information System
- EIS: Endoscopy Information System

- SCP: Service Class Provider
- SCU: Service Class User
- SOP: Service Object Pair
- TCP/IP: Transmission Control Protocol/Internet Protocol
- UID: Unique Identifier
- VR: Value Representation
- VL: Visual Light

2-5 References

The Digital Imaging and Communications in Medicine (DICOM) standard: (NEMA PS 3.X):

National Electrical Manufacturers Association (NEMA)

Publication Sales 1300 N. 17th Street, Suite 1847

Rosslyn, VA. 22209, USA

3. Networking

3-1 Implementation Model

3-1-1 Application Data Flow

3-1-1-1 Verification

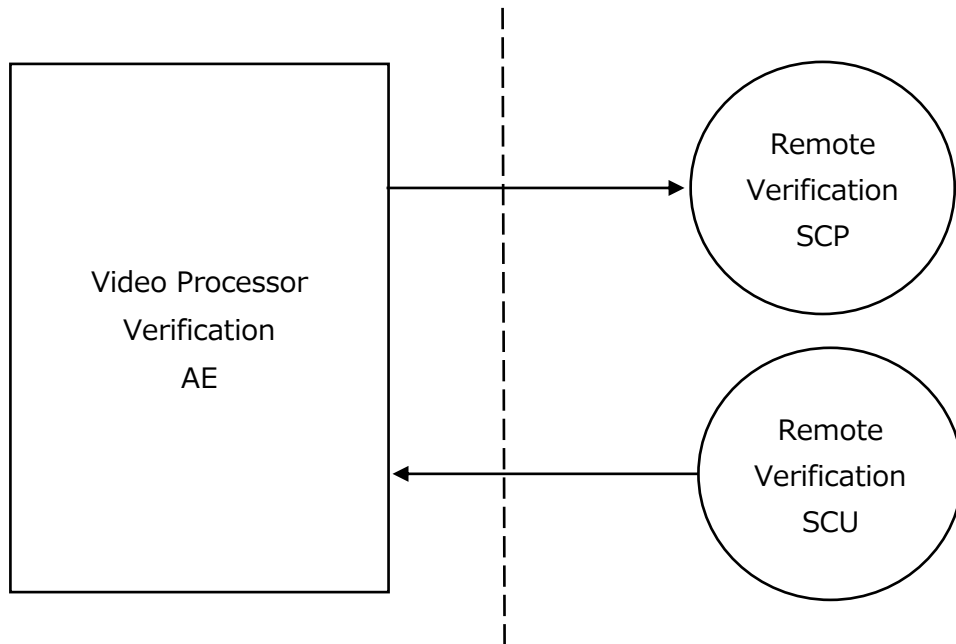

Figure 1. Verification Data Flow Diagram

3-1-1-2 Storage

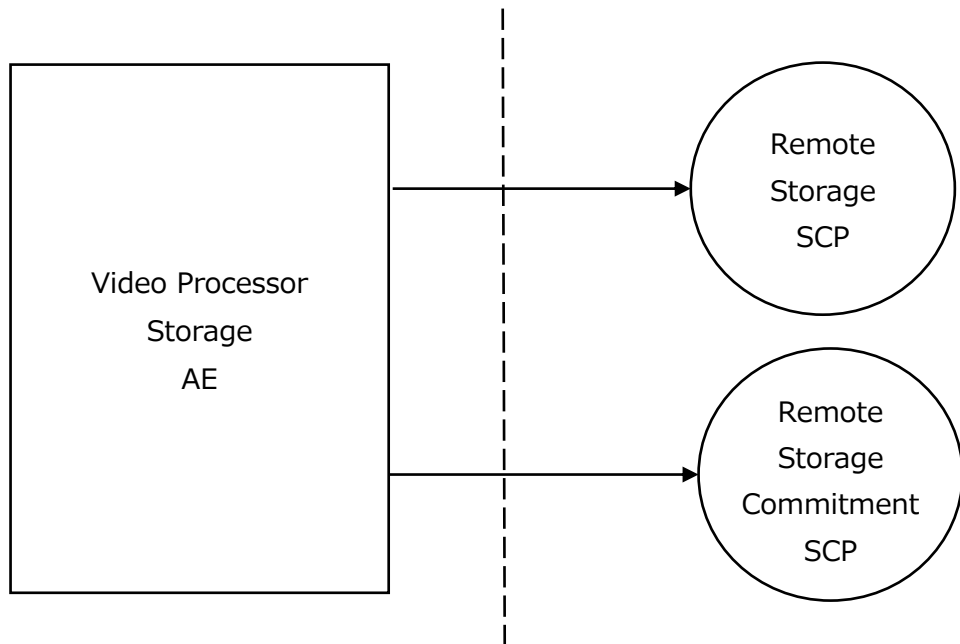

Figure 2. Storage Data Flow Diagram

3-1-1-3 Worklist Management

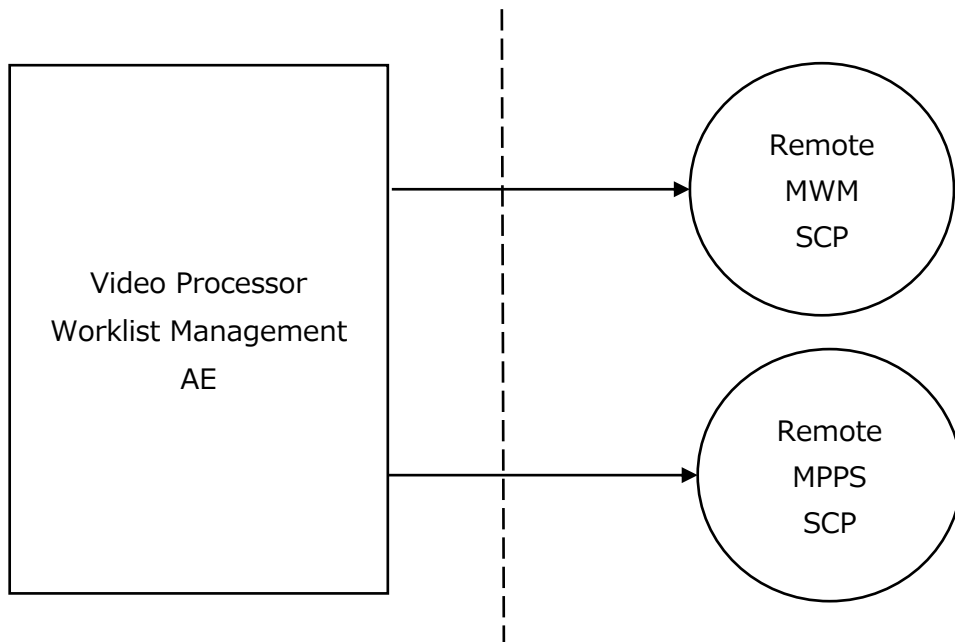

Figure 3. Worklist Management Data Flow Diagram

3-1-2 Functional Definition of EPK-i8020c AEs

Functional Definition of EPK-i8020c Storage Application Entity

The EPK-i8020c Storage AE creates and manages a send-job queue entry with associated network destination. An association request is sent to the destination AE and upon successful negotiation of a Presentation Context the image transfer is started. If the association cannot be opened, the related send-job is set to an error.

Functional Definition of EPK-i8020c Worklist Application Entity

Find attempts to download a Worklist from a remote node. If the EPK-i8020c Worklist AE establishes an Association to a remote AE, it will transfer all matching Worklist items via the open Association. The results are in a separate list, for the user select from.

3-1-3 Sequencing of Real-World Activities

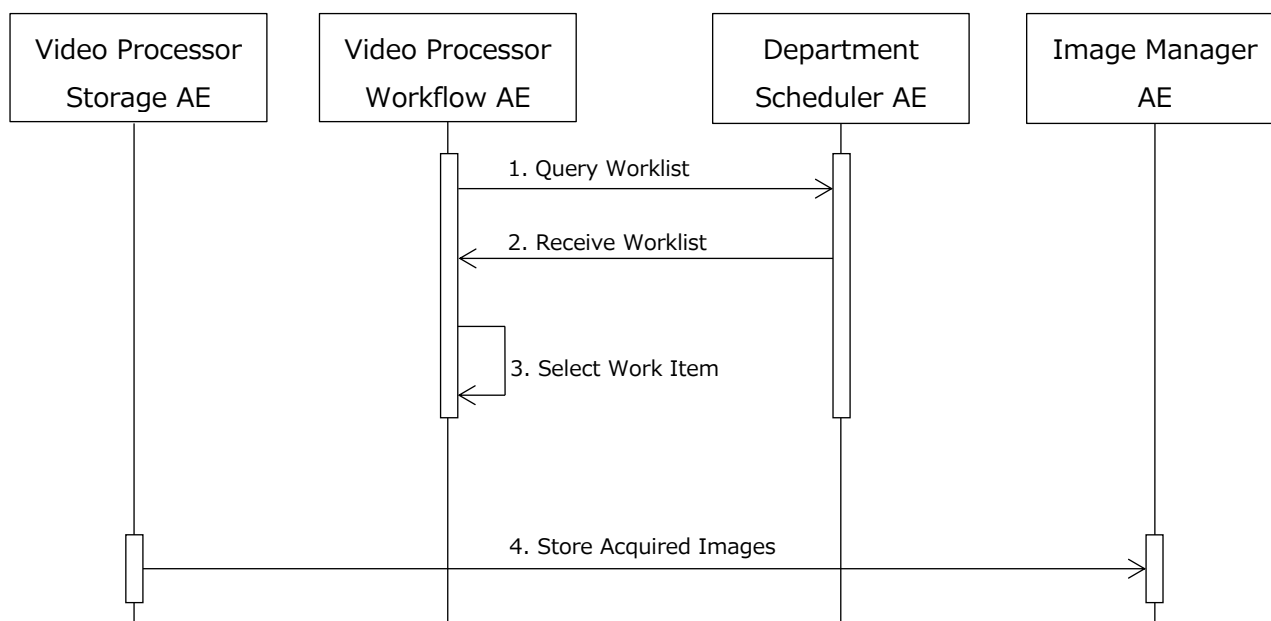

Figure 4. Sequencing of Constraints

Under normal scheduled worklist conditions, the sequencing constraints illustrated in Figure 4 apply:

1. Query Worklist
2. Receive Worklist Query results
3. Select Work Item
4. Acquire Images

Other worklist situations (e.g. unscheduled procedure steps) will have other sequencing constraints.

3-2 AE Specifications

3-2-1 EPK-i8020c Verification Application Entity Specification SOP Classes

EPK-i8020c provides Standard Conformance to the following SOP Classes :

Table 3. SOP Classes for AE EPK-i8020c Verification

SOP Class Name	SOP Class UID	SCU	SCP
Verification	1.2.840.10008.1.1	Yes	Yes

Association Policies

General

The DICOM standard application context name is always proposed:

Table 4. Application Context Name for the AE EPK-i8020c Verification

Application Context Name	1.2.840.10008.3.1.1.1
--------------------------	-----------------------

Number of Associations

EPK-i8020c initiates one Association at a time for each destination to which a transfer request is being processed in the active job queue list. Only one job per destination will be active at a time, other jobs cannot be executed until the active job is completed or failed.

Table 5. Number of Associations Initiated for the AE EPK-i8020c Verification

Maximum number of simultaneous Associations	1
---	---

Asynchronous Nature

EPK-i8020c does not support asynchronous communication (multiple outstanding transactions over a single Association).

Table 6. Asynchronous Nature as A SCU for AE EPK-i8020c Verification

Maximum number of outstanding asynchronous transactions	1
---	---

Implementation Identifying Information

The implementation information for this Application Entity is:

Table 7. DICOM Implementation Class and Version for AE EPK-i8020c Verification

Implementation Class UID	1.2.392.200269.8000
Implementation Version Name	EPK_I8000C

Association Initiation Policy

EPK-i8020c Verification AE attempts to initiate a new association to issue a C-ECHO request.

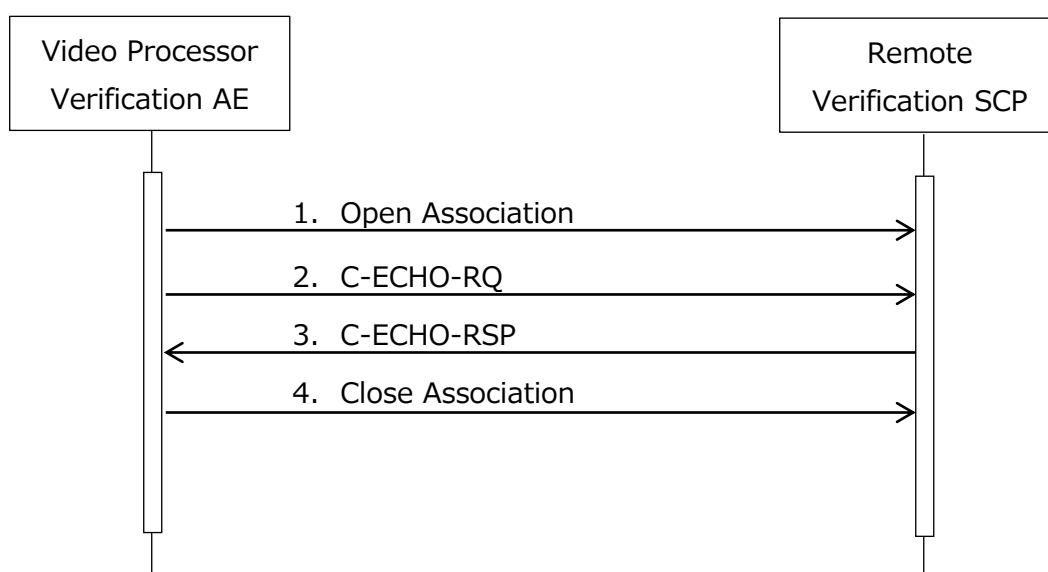

Figure 5. Sequencing of Activity - EPK-i8020c Verification

A possible sequence of interactions between the EPK-i8020c Verification AE and an Image Manager is illustrated in Figure 5:

1. The Verification AE opens an association with any Manager.
2. C-ECHO request is sent to each Manager.
3. Each Manager replies with a C-ECHO response (status success).
4. The Verification AE closes the association with any Manager.

Proposed Presentation Contexts

EPK-i8020c can propose the Presentation Contexts shown in the following table:

Table 8. Proposed Presentation Contexts for Activity Verification

Presentation Context Table					
Abstract Syntax		Transfer Syntax		Role	Ext. Neg.
Name	UID	Name List	UID List		
Verification	1.2.840.10008.1.1	Implicit VR Little Endian	1.2.840.10008.1.2	SCU	None
Verification	1.2.840.10008.1.1	Explicit VR Little Endian	1.2.840.10008.1.2.1	SCU	None

EPK-i8020c Verification AE replies to C-ECHO request from each Manager.

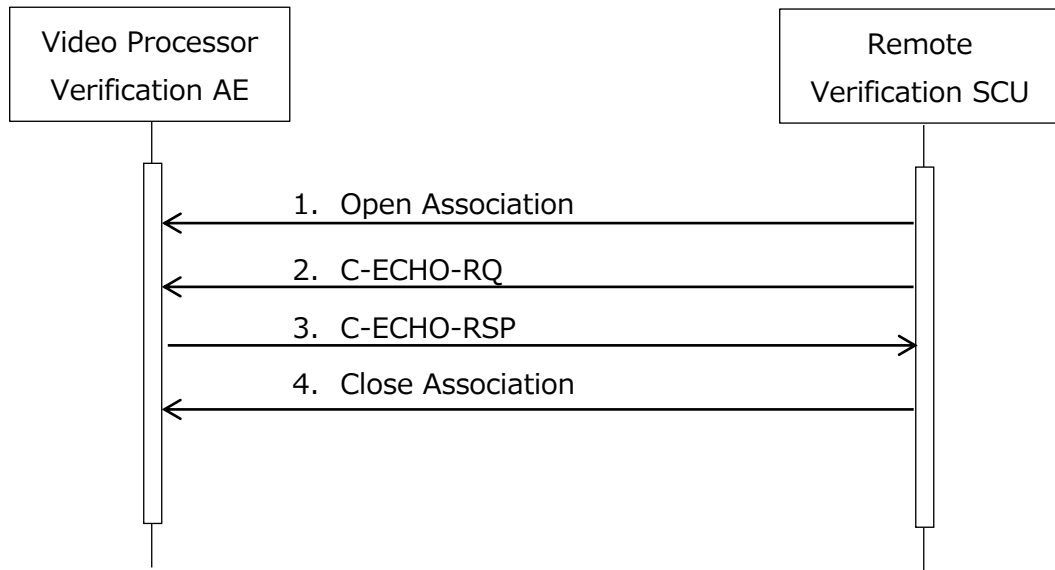

Figure 6. Sequencing of Activity - EPK-i8020c Receive Images

A possible sequence of interactions between the EPK-i8020c Verification AE and an Image Manager is illustrated in Figure 6:

1. Each Manager opens an association with the Verification AE.
2. Each Manager sends C-ECHO request to the Verification AE.
3. The Verification AE replies with a N-EVENT-REPORT response (status success).
4. Each Manager closes the association with the Verification AE.

Proposed Presentation Contexts

EPK-i8020c can propose the Presentation Contexts shown in the following table:

Table 9. Proposed Presentation Contexts for Activity Verification

Presentation Context Table					
Abstract Syntax		Transfer Syntax		Role	Ext. Neg.
Name	UID	Name List	UID List		
Verification	1.2.840.10008.1.1	Implicit VR Little Endian	1.2.840.10008.1.2	SCP	None

3-2-2 EPK-i8020c Storage Application Entity Specification SOP Classes

EPK-i8020c provides Standard Conformance to the following SOP Classes :

Table 10. SOP Classes for AE EPK-i8020c Storage

SOP Class Name	SOP Class UID	SCU	SCP
VL Endoscopic Image Storage	1.2.840.10008.5.1.4.1.1.77.1.1	Yes	No
Secondary Capture Image Storage	1.2.840.10008.5.1.4.1.1.7	Yes	No

Association Policies

General

The DICOM standard application context name is always proposed:

Table 11. DICOM Application Context for AE EPK-i8020c Storage

Application Context Name	1.2.840.10008.3.1.1.1
--------------------------	-----------------------

Number of Associations

EPK-i8020c initiates one Association at a time for each destination to which a transfer request is being processed in the active job queue list. Only one job will be active at a time, other jobs remain pending until the active job is completed or failed.

Table 12. Number of Associations Initiated for the AE EPK-i8020c Storage

Maximum number of simultaneous Associations	1
---	---

Asynchronous Nature

EPK-i8020c does not support asynchronous communication (multiple outstanding transactions over a single Association).

Table 13. Asynchronous Nature as A SCU for AE EPK-i8020c Storage

Maximum number of outstanding asynchronous transactions	1
---	---

Implementation Identifying Information

The implementation information for this Application Entity is:

Table 14. DICOM Implementation Class and Version for AE EPK-i8020c Storage

Implementation Class UID	1.2.392.200269.8000
Implementation Version Name	EPK_I8000C

Association Initiation Policy

Activity - Send Images

Description and Sequencing of Activities

A user can request that the entire image be sent to the configured destination. Each request is forwarded to the job queue and processed individually.

The EPK-i8020c Storage AE attempts to initiate a new association to issue a C-STORE request.

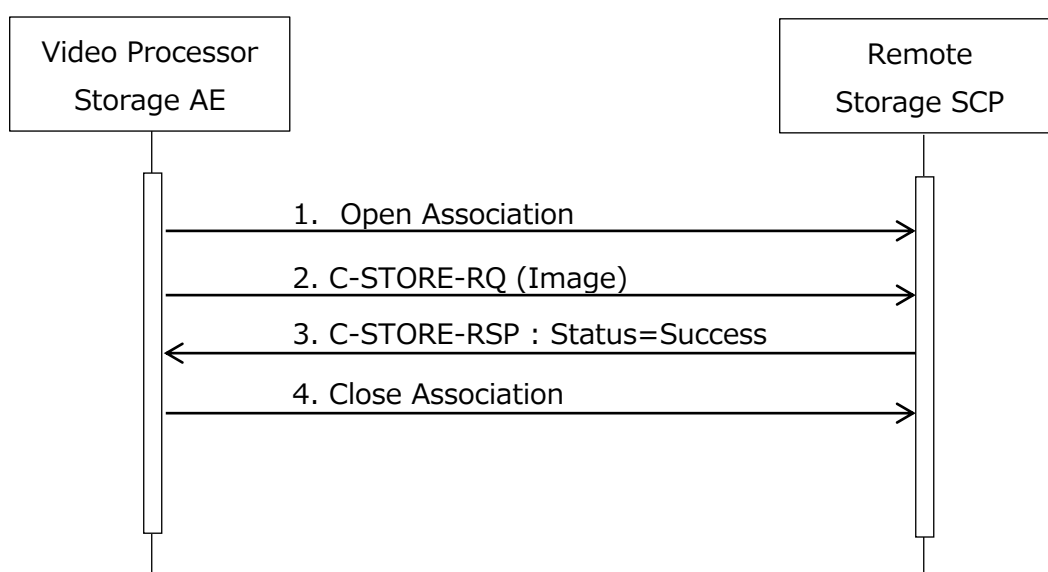

Figure 7. Sequencing of Activity - EPK-i8020c Send Images

A possible sequence of interactions between the EPK-i8020c Storage AE and an Image Manager is illustrated in Figure 7:

1. The Storage AE opens an association with the Image Manager.
2. An acquired image is transmitted to the Image Manager using a C-STORE request.
3. The Image Manager replies with a C-STORE response (status success).
4. The Storage AE closes the association with the Image Manager.

Proposed Presentation Contexts

EPK-i8020c can propose the Presentation Contexts shown in the following table:

Table 15. Proposed Presentation Contexts for Activity Send Images

Presentation Context Table					
Abstract Syntax		Transfer Syntax		Role	Ext. Neg.
Name	UID	Name List	UID List		
VL Endoscopic Image Storage (Video not supported)	1.2.840.10008.5.1.4 .1.1.77.1.1	Implicit VR Little Endian (Default)	1.2.840.10008.1.2	SCU	None
		Explicit VR Little Endian	1.2.840.10008.1.2 .1		
		JPEG Lossy Baseline	1.2.840.10008.1.2 .4.50		
Secondary Capture Image Storage (Video not supported)	1.2.840.10008.5.1.4 .1.1.7	Implicit VR Little Endian (Default)	1.2.840.10008.1.2	SCU	None
		Explicit VR Little Endian	1.2.840.10008.1.2 .1		
		JPEG Lossy Baseline	1.2.840.10008.1.2 .4.50		

SOP Specific Conformance Image & Pre State Storage SOP Classes

All Image & Presentation State Storage SOP Classes supported by the EPK-i8020c Storage AE exhibit the same behavior, except where stated, and are described together in this section.

The behavior of EPK-i8020c Storage AE when encountering status codes in a C-STORE response is summarized in the Table below:

Table 16. Storage C- STORE Response Status Handling Behavior

Service Status	Further Meaning	Error Code	Behavior
Success	Success	0000	The SCP has successfully received the SOP Instance. If all SOP Instances in a send job have status success, then the job is marked as complete.
Failed	*	Any other status codes.	The job failure is reported to the user via the background job control application.

The behavior of Storage AE during communication failure is summarized in the Table below:

Table 17. Storage Communication Failure Behavior

Exception	Behavior
Association aborted by the SCP or network layers	The send job is marked as failed. The job failure is reported to the user via the background job control application.

3-2-3 EPK-i8020c Storage Commitment Application Entity Specification SOP Classes

EPK-i8020c provides Standard Conformance to the following SOP Classes :

Table 18. SOP Classes for AE EPK-i8020c Storage Commitment

SOP Class Name	SOP Class UID	SCU	SCP
Storage Commitment Push Model	1.2.840.10008.1.20.1	Yes	No

Association Policies

General

The DICOM standard application context name is always proposed:

Table 19. DICOM Application Context for AE EPK-i8020c Storage Commitment

Application Context Name	1.2.840.10008.3.1.1.1
--------------------------	-----------------------

Number of Associations

EPK-i8020c initiates one association at a time for a Storage Commitment request.

Table 20. Number of Associations Initiated for the AE EPK-i8020c Storage Commitment

Maximum number of simultaneous Associations	1
---	---

Asynchronous Nature

EPK-i8020c does not support asynchronous communication (multiple outstanding transactions over a single Association).

Table 21. Asynchronous Nature as A SCU for AE EPK-i8020c Storage Commitment

Maximum number of outstanding asynchronous transactions	1
---	---

Implementation Identifying Information

The implementation information for this Application Entity is:

Table 22. DICOM Implementation Class and Version for AE EPK-i8020c Storage Commitment

Implementation Class UID	1.2.392.200269.8000
Implementation Version Name	EPK_I8000C

Association Initiation Policy

Activity - Send Images

Description and Sequencing of Activities

A user can request that the entire image be sent to the configured destination. Each request is forwarded to the job queue and processed individually.

When Storage AE performs transmission using Storage Commitment, it sends C-STORE request to Image Manager. After it receives C-STORE response (status success) from the Image Manager, it performs the following sequence in addition.

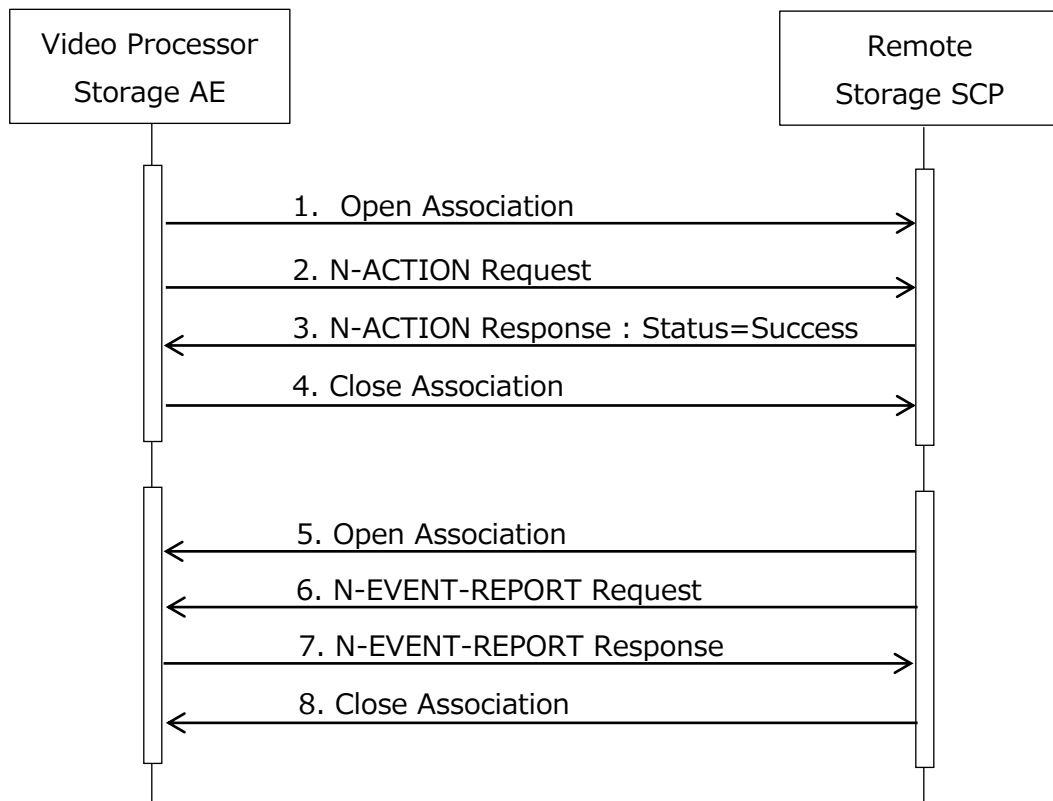

Figure 8. Sequencing of Activity - EPK-i8020c Send Images

A possible sequence of interactions between the EPK-i8020c Storage AE and an Image Manager is illustrated in Figure 8:

1. The Storage AE opens an association with the Image Manager.
2. An N-ACTION request is sent to the Image Manager.
3. The Image Manager replies with a N-ACTION response (status success).
4. The Storage AE closes the association with the Image Manager.
5. The Image Manager opens an association with the Storage AE.
6. The Image Manager sends an N-EVENT-REPORT request to the Storage AE.
7. The Storage AE replies with a N-EVENT-REPORT response (status success).
8. The Image Manager closes the association with the Storage AE.

Proposed Presentation Contexts

EPK-i8020c can propose the Presentation Contexts shown in the following table:

Table 23. Proposed Presentation Contexts for Activity Send Images Commitment

Presentation Context Table					
Abstract Syntax		Transfer Syntax		Role	Ext. Neg.
Name	UID	Name List	UID List		
Storage Commitment Push Model	1.2.840.10008.1.20.1	Implicit VR Little Endian	1.2.840.10008.1.2	SCP	None
		Explicit VR Little Endian	1.2.840.10008.1.2 .1		

SOP Specific Conformance Image & Pre State Storage SOP Classes

All Image & Presentation State Storage SOP Classes supported by the EPK-i8020c Storage AE exhibit the same behavior, except where stated, and are described together in this section.

The behavior of EPK-i8020c Storage AE when encountering status codes in a N-ACTION response is summarized in the Table below:

Table 24. Storage N-ACTION Response Status Handling Behavior

Service Status	Further Meaning	Error Code	Behavior
Success	Success	0000	The SCP has successfully received the SOP Instance. If all SOP Instances in a send job have status success, then the job is marked as complete.
Failed	*	Any other status codes.	The job failure is reported to the user via the background job control application.

The behavior of Storage AE during communication failure is summarized in the Table below:

Table 25. Storage Communication Failure Behavior

Exception	Behavior
Association aborted by the SCP or network layers	The send job is marked as failed.

3-2-4 EPK-i8020c Worklist Application Entity Specification SOP Classes

EPK-i8020c provides Standard Conformance to the following SOP Classes :

Table 26. SOP Classes for AE EPK-i8020c Worklist

SOP Class Name	SOP Class UID	SCU	SCP
Modality Worklist Information Model - FIND	1.2.840.10008.5.1.4.31	Yes	No

Association Policies

General

The DICOM standard application context name is always proposed:

Table 27. DICOM Application Context for AE EPK-i8020c Worklists

Application Context Name	1.2.840.10008.3.1.1.1
--------------------------	-----------------------

Number of Associations

EPK-i8020c initiates one association at a time for a worklist request.

Table 28. Number of Associations Initiated for AE EPK-i8020c Worklist

Maximum number of simultaneous Associations	1
---	---

Asynchronous Nature

EPK-i8020c does not support asynchronous communication (multiple outstanding transactions over a single Association).

Table 29. Asynchronous Nature as A SCU for EPK-i8020c Worklist

Maximum number of outstanding asynchronous transactions	1
---	---

Implementation Identifying Information

The implementation information for this Application Entity is:

Table 30. DICOM Implementation Class and Version for AE EPK-i8020c Worklist

Implementation Class UID	1.2.392.200269.8000
Implementation Version Name	EPK_I8000C

Association Initiation Policy

Activity - Worklist Update

Description and Sequencing of Activities

Upon initiation of the request, the EPK-i8020c will build an Identifier for the C-FIND request, will initiate an Association to send the request and will wait for worklist responses. After retrieval of all responses, the EPK-i8020c will access the local database to update the patient data. To protect the system from overflow, the EPK-i8020c will limit the number of processed worklist responses to a configurable maximum. The results will be displayed in a separate list, which will be cleared with the next worklist update.

EPK-i8020c integrated modality will initiate an Association to issue a C-FIND request according to the Modality Worklist Information Model.

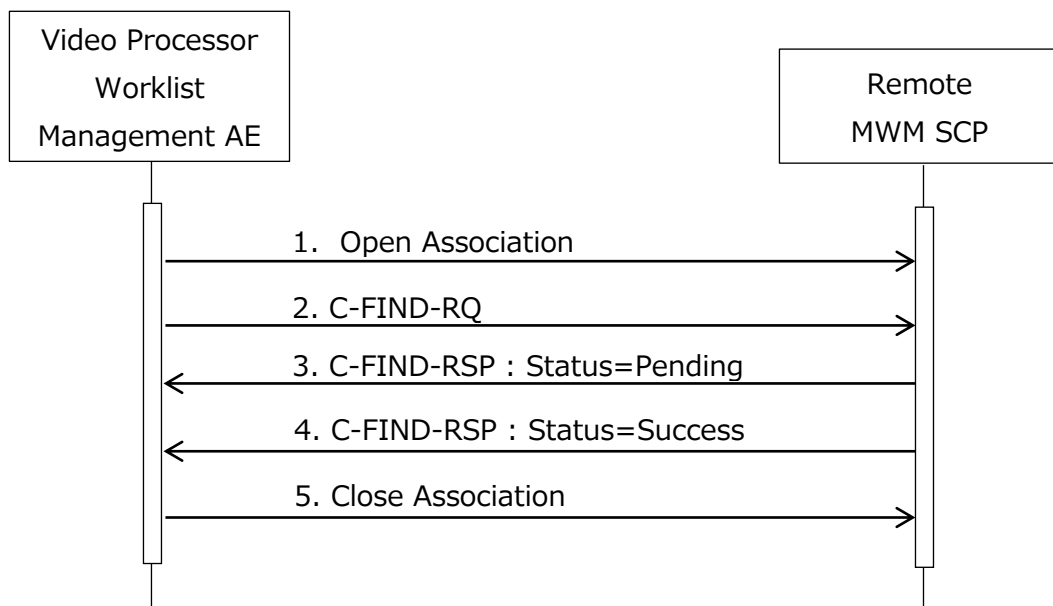

Figure 9. Sequencing of Activity - Worklist Update

A possible sequence of interactions between the EPK-i8020c Worklist AE and a Departmental Scheduler (e.g. a device such as a RIS (EIS) or HIS which supports the Modality Worklist SOP Class as an SCP) is illustrated in Figure 9:

1. The EPK-i8020c Worklist AE opens an association with a Departmental Scheduler.
2. The EPK-i8020c Worklist AE sends a C-FIND request to the Departmental Scheduler containing the worklist.
3. The Departmental Scheduler returns a C-FIND response containing the requested attributes of the matching worklist Item.
4. The Departmental Scheduler returns another C-FIND response with status Success indicating that no further matching worklist Items exist.
5. The Worklist AE closes the association with a Departmental Scheduler.

Proposed Presentation Contexts

EPK-i8020c will propose Presentation Contexts as shown in the following table:

Table 31. Proposed Presentation Contexts for Activity Worklist Update

Presentation Context Table					
Abstract Syntax		Transfer Syntax		Role	Ext. Neg.
Name	UID	Name List	UID List		
Modality Worklist Information Model - FIND	1.2.840.10008.5.1.4.31	Implicit VR Little Endian	1.2.840.10008.1.2	SCU	None
Modality Worklist Information Model - FIND	1.2.840.10008.5.1.4.31	Explicit VR Little Endian	1.2.840.10008.1.2.1	SCU	None

Table 32. Modality Worklist Query Criteria

Data Used	Input
Study Date or AE Title or Modality <i>(Configurable)</i>	If not entered by user, the results assigned on the day of execution will be displayed.

SOP Specific Conformance for Modality Worklist

The behavior of EPK-i8020c when encountering status codes in a Modality Worklist C-FIND response is summarized in the Table below.

Table 33. Modality Worklist C-FIND Response Status-Handling Behavior

Service Status	Further Meaning	Error Code	Behavior
Success	Matching is complete	0000	The SCP has completed the matches.
Failed	*	Any other status codes.	The job failure is reported to the user via the background job control application.

Acquired images will always use the Study Instance UID specified for the Scheduled Procedure Step (if available).

Requested return attributes not supported by the SCP are set to have no value. Non-matching responses returned by the SCP due to unsupported optional matching keys are ignored. No attempt is made to filter out possible duplicate entries.

Table 34. Worklist Request Identifiers

Attribute Name	Tag	VR	Matching type
Study Date	(0008,0020)	DA	-
Study Time	(0008,0030)	TM	-
Accession Number	(0008,0050)	SH	-
Modality	(0008,0060)	CS	Search key
Referring Physician's Name	(0008,0090)	PN	-
Patient's Name	(0010,0010)	PN	-
Patient ID	(0010,0020)	LO	-
Patients Birth Date	(0010,0030)	DA	-
Patient's Sex	(0010,0040)	CS	-
Patient's Age	(0010,1010)	AS	-
Patient's Comments	(0010,4000)	LT	-
Study Instance UID	(0020,000D)	UI	-
Scheduled Procedure Step Sequence	(0040,0100)	SQ	-
Scheduled Station AE Title	(0040,0001)	AE	Search key
Scheduled Procedure Step Start Date	(0040,0002)	DA	Search key

EPK-i8020c provides Standard Conformance to the following SOP Classes :

Table 35. SOP Classes for AE EPK-i8020c Modality Performed Procedure Step

SOP Class Name	SOP Class UID	SCU	SCP
Modality Performed Procedure Step	1.2.840.10008.3.1.2.3.3	Yes	No

Association Policies

General

The DICOM standard application context name is always proposed:

Table 36. DICOM Application Context for AE EPK-i8020c Modality Performed Procedure Step

Application Context Name	1.2.840.10008.3.1.1.1
--------------------------	-----------------------

Number of Associations

EPK-i8020c initiates one association at a time for a Modality Performed Procedure Step request.

Table 37. Number of Associations Initiated for AE EPK-i8020c Modality Performed Procedure Step

Maximum number of simultaneous Associations	1
---	---

Asynchronous Nature

EPK-i8020c does not support asynchronous communication (multiple outstanding transactions over a single Association).

Table 38. Asynchronous Nature as A SCU for EPK-i8020c Modality Performed Procedure Step

Maximum number of outstanding asynchronous transactions	1
---	---

Implementation Identifying Information

The implementation information for this Application Entity is:

Table 39. DICOM Implementation Class and Version for AE EPK-i8020c

Modality Performed Procedure Step

Implementation Class UID	1.2.392.200269.8000
Implementation Version Name	EPK_I8000C

Association Initiation Policy

Activity - Worklist Update

Description and Sequencing of Activities

Start/end of Modality Performed Procedure Step is transmitted according to the user operation. That is, an interactive query for "examination start" is executable when the user starts a new examination; and an interactive query for "examination end" is executable when the user state changes from "under examination" to "examination end".

However, for the examination that has not been acquired from the MWM server, i.e., the examination started by entry to the EPK-i8020c, transmission regarding Modality Performed Procedure Step is not executed.

The EPK-i8020c will initiate an Association to issue N-CREATE / N-SET request in accordance with Modality Performed Procedure Step Information Model.

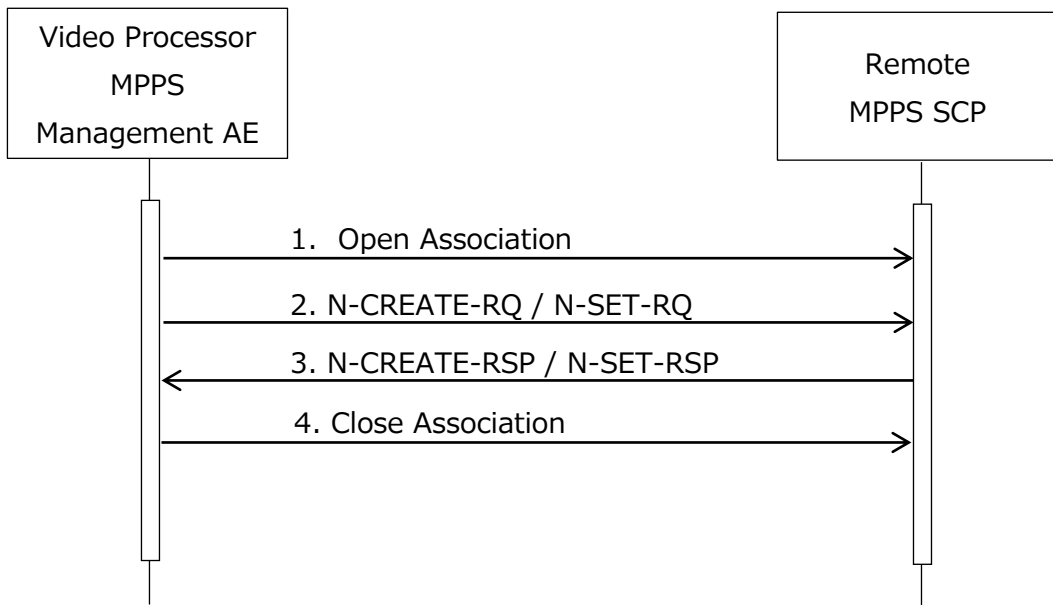

Figure 10. Sequencing of Activity - Worklist Update

A possible sequence of interactions between the EPK-i8020c Modality Performed Procedure Step AE and a Departmental Scheduler (e.g. a device such as a RIS (EIS) or HIS which supports the Modality Performed Procedure Step SOP Class as an SCP) is illustrated in Figure 10:

1. The EPK-i8020c Modality Performed Procedure Step AE opens an association with the Departmental Scheduler.
2. The EPK-i8020c Modality Performed Procedure Step AE sends a N-CREATE / N-SET request to the Departmental Scheduler.
3. The Departmental Scheduler replies with a N-CREATE / N-SET response (status success).
4. The Modality Performed Procedure Step AE closes the association with the Departmental Scheduler.

Proposed Presentation Contexts

EPK-i8020c will propose Presentation Contexts as shown in the following table:

Table 40. Proposed Presentation Contexts for Activity Worklist Update

Presentation Context Table					
Abstract Syntax		Transfer Syntax		Role	Ext. Neg.
Name	UID	Name List	UID List		
Modality Performed Procedure Step	1.2.840.10008.3.1.2.3. 3	Implicit VR Little Endian	1.2.840.10008.1.2	SCU	None
Modality Performed Procedure Step	1.2.840.10008.3.1.2.3. 3	Explicit VR Little Endian	1.2.840.10008.1.2.1	SCU	None

SOP Specific Conformance for Modality Performance Procedure Step

The EPK-i8020c Modality Performance Procedure Step AE provides standard conformance to the Verification SOP Class as an SCP. If N-CREATE / N-SET request is successfully received, a 0000 (Success) status code will be returned in the N-CREATE / N-SET response.

Table 41. Modality Performance Procedure Step N-CREATE/N-SET Response Status-Handling Behavior

Service Status	Further Meaning	Error Code	Behavior
Success	Success	0000	The SCP has successfully transmitted the SOP Instance. If all SOP Instances in a send job have status success, then the job is marked as complete.
Failed	*	Any other status codes.	The job failure is reported to the user via the background job control application.

The behavior of Modality Performance Procedure Step AE during communication failure is summarized in the Table below:

Table 42. Modality Performance Procedure Step Communication Failure Behavior

Exception	Behavior
Association aborted by the SCP or network layers	The Modality Performance Procedure Step is marked as failed. The job failure is reported to the user.

Table 43. Modality Performance Procedure Step Identifiers

Attribute Name	Tag	VR	N-CREATE	N-SET
Specific Character Set	(0008,0005)	CS	x	x
Accession Number	(0008,0050)	SH	x	-
Modality	(0008,0060)	CS	x	-
Procedure Code Sequence	(0008,1032)	SQ	x	-
Referenced Study Sequence	(0008,1110)	SQ	x	-
Referenced Patient Sequence	(0008,1120)	SQ	x	-
Patient's Name	(0010,0010)	PN	x	-
Patient ID	(0010,0020)	LO	x	-
Patient's Birth Date	(0010,0030)	DA	x	-
Patient's Sex	(0010,0040)	CS	x	-
Study Instance UID	(0020,000D)	UI	x	-
Study ID	(0020,0010)	SH	x	-
Requested Procedure Description	(0032,1060)	LO	x	-
Scheduled Procedure Step Description	(0040,0007)	LO	x	-
Scheduled Protocol Code Sequence	(0040,0008)	SQ	x	-
Scheduled Procedure Step ID	(0040,0009)	SH	x	-
Performed Station AE Title	(0040,0241)	AE	x	-
Performed Station Name	(0040,0242)	SH	x	-
Performed Location	(0040,0243)	SH	x	-
Performed Procedure Step Start Date	(0040,0244)	DA	x	-
Performed Procedure Step Start Time	(0040,0245)	TM	x	-
Performed Procedure Step End Date	(0040,0250)	DA	x	x
Performed Procedure Step End Time	(0040,0251)	TM	x	x
Performed Procedure Step Status	(0040,0252)	CS	x	x
Performed Procedure Step ID	(0040,0253)	SH	x	-
Performed Procedure Step Description	(0040,0254)	LO	x	x
Performed Procedure Type Description	(0040,0255)	LO	x	x
Performed Protocol Code Sequence	(0040,0260)	SQ	x	-
Scheduled Step Attributes Sequence	(0040,0270)	SQ	x	-
Performed Series Sequence	(0040,0340)	SQ	x	x
Requested Procedure ID	(0040,1001)	SH	x	-
Retrieve AE Title	(0008,0054)	AE	-	x
Series Description	(0008,103E)	LO	-	x
Performing Physician's Name	(0008,1050)	PN	-	x
Operators Name	(0008,1070)	PN	-	x
Referenced Image Sequence	(0008,1140)	SQ	-	x

Protocol Name	(0018,1030)	LO	-	x
Series Instance UID	(0020,000E)	UI	-	x
Referenced Non-Image Composite SOP Instance Sequence	(0040,0220)	SQ	-	x

3-2-6 Association Acceptance Policy

EPK-i8020c Application Entity accepts Associations.

3-3 NETWORK INTERFACES

3-3-1 Physical Network Interface

EPK-i8020c supports a single network interface. One of the following physical network interfaces will be available depending on installed hardware options

Table 44. Supported Physical Network Interfaces

Ethernet 1000base-T

3-3-2 Additional Protocols

DHCP and DNS

The EPK-i8020c does not support DHCP and DNS to respond to Verification queries from each server. Configure the TCP/IP network configuration information manually.

3-4 CONFIGURATION

3-4-1 AE Title/Presentation Address Mapping Local AE Titles

All local applications use the AE Titles and TCP/IP ports configured via the Configuration Panel. The Field Service Engineer can configure the TCP port via the Configuration Tool. The default AE Title is as follows. The local applications cannot configure the AE Title independently. All local AEs use the same AE Titles.

Table 45. AE Title Configuration Table

Application Entity	Default AE Title	Default TCP/IP Port
Modality	INSPIRA	50107

Remote AE Title/Presentation Address Mapping

Set the AE Title and port number of each server as those for the remote application.

Storage

On/off of the remote storage can be set from EPK-i8020c. It is necessary to set the AE Title, port number, IP address, and function of the remote storage. Associations will only be accepted from known AE Titles and associations from unknown AE Titles will be rejected. Only one remote storage can be defined. Also, on/off of Commitment, and Compression functions can be set.

Refer to Storage Commitment Push Model in Table 18 for Standard Conformance to the SOP class required for the Commitment function.

Worklist

On/off of the remote Worklist can be set from EPK-i8020c. It is necessary to set the AE Title, port number, IP address, and function of the remote Worklist. Only one remote Worklist can be defined.

Modality Performed Procedure Step

On/off of the remote Modality Performed Procedure Step can be set from EPK-i8020c. It is necessary to set the AE Title, port number, IP address, and function of the remote Modality Performed Procedure Step. Only one remote Modality Performed Procedure Step can be defined.

4. Support of Character Sets

The EPK-i8020c DICOM applications support transmission/reception of the following character sets.

Table 46. Support of Character sets

Character Set Description	Defined Term	Supported Languages
Latin 1 (ISO8859-1)	ISO_IR 100	English, Spanish, French, Italian, Irish, Portuguese, Dutch, Swedish, Danish, Norwegian, Finnish, German
Latin 2 (ISO8859-2)	ISO_IR 101	Czech, Hungarian, Slovenian, Slovak, Polish, Croatian
Latin 3 (ISO8859-3)	ISO_IR 109	Multi
Latin 4 (ISO8859-4)	ISO_IR 110	Latvian, Lithuanian
Cyrillic (ISO8859-5)	ISO_IR 144	Russian, Bulgarian, Macedonian
Greek (ISO8859-7)	ISO_IR 126	Greek
Latin 5 (ISO8859-9)	ISO_IR 148	Turkish
Latin 9 (ISO8859-15)	ISO_IR 203	Estonian
Latin 10 (ISO8859-16)	ISO_IR 226	Romanian
Japanese	ISO_IR 13 ISO_IR 87	Japanese
Chinese	GB18030	Chinese
Unicode in UTF-8	ISO_IR 192	

5. Security

This product does not support any DICOM specific security measures.

6. Appendix

6-1 VL Endoscopic Image Storage IOD specifications

Table 47. VL Endoscopic Image Storage IOD specifications

Patient Module PS3.3 section C.7.1.1				
Attribute Name	Element Tag	VR	Type	Source
Patient's name	0010, 0010	PN	2	MWM or Modality
Patient ID	0010, 0020	LO	2	MWM or Modality
Patient's birth date	0010, 0030	DA	2	MWM or Modality
Patient sex	0010, 0040	CS	2	MWM or Modality
Patient comments	0010, 4000	LT	3	MWM or Modality
General Study Module PS3.3 section C.7.2.1				
Attribute Name	Element Tag	VR	Type	Source
Study instance UID	0020, 000D	UI	1	MWM or Modality
Study date	0008, 0020	DA	2	Modality
Study time	0008, 0030	TM	2	Modality
Referring physician's name	0008, 0090	PN	2	MWM or Modality
Study ID	0020, 0010	SH	2	Modality
Accession number	0008, 0050	SH	2	MWM or Modality
Patient Study Module PS3.3 section C.7.2.2				
Attribute Name	Element Tag	VR	Type	Source
Patient's age	0010, 1010	AS	3	MWM or Modality
General Series Module PS3.3 section C.7.3.1				
Attribute Name	Element Tag	VR	Type	Source
Modality	0008, 0060	CS	1	Modality
Series instance UID	0020, 000E	UI	1	Modality
Series Number	0020, 0011	IS	2	Modality
Series date	0008, 0021	DA	3	Modality
Series time	0008, 0031	TM	3	Modality
General Equipment Module PS3.3 section C.7.5.1				
Attribute Name	Element Tag	VR	Type	Source
Manufacturer	0008, 0070	LO	2	Modality
Institution name	0008, 0080	LO	3	Modality
Manufacturer's model name	0008, 1090	LO	3	Modality
Device serial number	0018, 1000	LO	3	Modality
Software version	0018, 1020	LO	3	Modality
General Image Module PS3.3 section C.7.6.1				

Attribute Name	Element Tag	VR	Type	Source
Instance number	0020, 0013	IS	2	Modality
Patient Orientation	0020, 0020	CS	2C	Modality
Content date	0008, 0023	DA	2C	Modality
Image Pixel Module PS3.3 section C.7.6.3				
Attribute Name	Element Tag	VR	Type	Source
Pixel data	7FE0, 0010	OB	1C	Modality
Rows	0028, 0010	US	1	Modality
Columns	0028, 0011	US	1	Modality
Pixel aspect ratio	0028, 0034	IS	1C	Modality
Acquisition Context Module PS3.3 section C.7.6.14				
Attribute Name	Element Tag	VR	Type	Source
Acquisition context sequence	0040, 0555	SQ	2	Modality
VL Image Module PS3.3 section C.8.12.1				
Attribute Name	Element Tag	VR	Type	Source
Image type	0008, 0008	CS	1	Modality
Photometric Interpretation	0028, 0004	CS	1	Modality
Bits allocated	0028, 0100	US	1	Modality
Bits stored	0028, 0101	US	1	Modality
High bit	0028, 0102	US	1	Modality
Pixel representation	0028, 0103	US	1	Modality
Samples per pixel	0028, 0002	US	1	Modality
Planar configuration	0028, 0006	US	1C	Modality
Content time	0008, 0033	TM	1C	Modality
Lossy image compression	0028, 2110	CS	2	Modality
SOP Common Module PS3.3 section C.12.1				
Attribute Name	Element Tag	VR	Type	Source
SOP class UID	0008, 0016	UI	1	Modality
SOP instance UID	0008, 0018	UI	1	Modality
Specific character set	0008, 0005	CS	1C	MWM or Modality

Table 48. Secondary Capture Image Storage IOD specifications

Patient Module PS3.3 section C.7.1.1				
Attribute Name	Element Tag	VR	Type	Source
Patient's name	0010, 0010	PN	2	MWM or Modality
Patient ID	0010, 0020	LO	2	MWM or Modality
Patient's birth date	0010, 0030	DA	2	MWM or Modality
Patient sex	0010, 0040	CS	2	MWM or Modality
Patient comments	0010, 4000	LT	3	MWM or Modality
General Study Module PS3.3 section C.7.2.1				
Attribute Name	Element Tag	VR	Type	Source
Study instance UID	0020, 000D	UI	1	MWM or Modality
Study date	0008, 0020	DA	2	Modality
Study time	0008, 0030	TM	2	Modality
Referring physician's name	0008, 0090	PN	2	MWM or Modality
Study ID	0020, 0010	SH	2	Modality
Accession number	0008, 0050	SH	2	MWM or Modality
Patient Study Module PS3.3 section C.7.2.2				
Attribute Name	Element Tag	VR	Type	Source
Patient's age	0010, 1010	AS	3	MWM or Modality
SC Equipment Module PS3.3 section C.8.6.1				
Attribute Name	Element Tag	VR	Type	Source
Modality	0008, 0060	CS	3	Modality
Conversion Type	0008, 0064	CS	1	Modality
General Series Module PS3.3 section C.7.3.1				
Attribute Name	Element Tag	VR	Type	Source
Series instance UID	0020, 000E	UI	1	Modality
Series Number	0020, 0011	IS	2	Modality
Series date	0008, 0021	DA	3	Modality
Series time	0008, 0031	TM	3	Modality
General Equipment Module PS3.3 section C.7.5.1				
Attribute Name	Element Tag	VR	Type	Source
Manufacturer	0008, 0070	LO	2	Modality
Institution name	0008, 0080	LO	3	Modality
Manufacturer's model name	0008, 1090	LO	3	Modality
Device serial number	0018, 1000	LO	3	Modality
Software version	0018, 1020	LO	3	Modality
General Image Module PS3.3 section C.7.6.1				
Attribute Name	Element Tag	VR	Type	Source

Instance number	0020, 0013	IS	2	Modality
Patient Orientation	0020, 0020	CS	2C	Modality
Content date	0008, 0023	DA	2C	Modality
Content time	0008, 0033	TM	2C	Modality
Image type	0008, 0008	CS	3	Modality
Lossy image compression	0028, 2110	CS	3	Modality
Image Pixel Module PS3.3 section C.7.6.3				
Attribute Name	Element Tag	VR	Type	Source
Pixel data	7FE0, 0010	OB	1C	Modality
Samples per pixel	0028, 0002	US	1	Modality
Photometric Interpretation	0028, 0004	CS	1	Modality
Rows	0028, 0010	US	1	Modality
Columns	0028, 0011	US	1	Modality
Pixel aspect ratio	0028, 0034	IS	1C	Modality
Bits allocated	0028, 0100	US	1	Modality
Bits stored	0028, 0101	US	1	Modality
High bit	0028, 0102	US	1	Modality
Pixel representation	0028, 0103	US	1	Modality
Planar configuration	0028, 0006	US	1C	Modality
SOP Common Module PS3.3 section C.12.1				
Attribute Name	Element Tag	VR	Type	Source
SOP class UID	0008, 0016	UI	1	Modality
SOP instance UID	0008, 0018	UI	1	Modality
Specific character set	0008, 0005	CS	1C	MWM or Modality
SC Image Module PS3.3 section C.8.6.2				
Attribute Name	Element Tag	VR	Type	Source
Date of Secondary Capture	0018, 1012	DA	3	Modality
Time of Secondary Capture	0018, 1014	TM	3	Modality